

Typical Circuit Diagram.

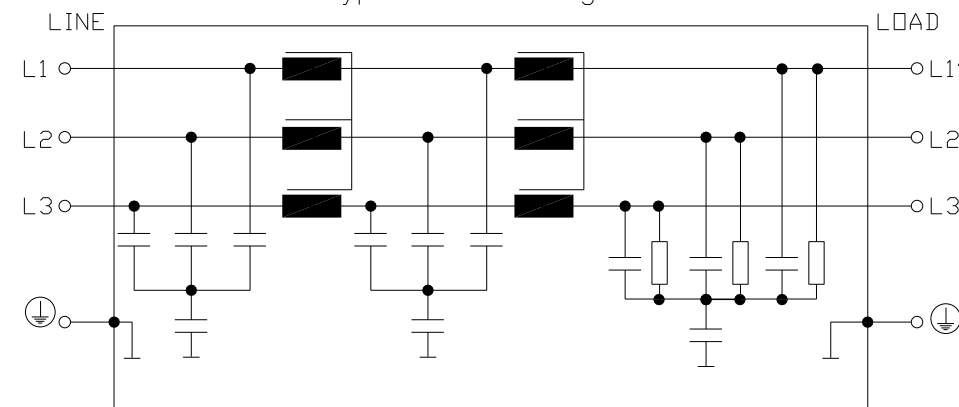

Technical data and measuring conditions.

Rated Voltage V_R	760/440 V AC, 50/60Hz.
Rated Current I_R	Referred to 40 °C ambient temperature
Test Voltage V_{test}	3270 V DC, 2 s (line/line) 2890 V DC, 2 s (line/case)
Overload Capability (thermal)	1.5 · I_R for 3 min per hour or 2.5 · I_R for 30 s per hour
Leakage Current I_{leak}	At 760 V AC, 50 Hz.
Climatic Category (IEC 60068-1)	25/100/21 (-25 °C/+100 °C/21 days damp heat test)
Approvals	UL 1283, CSA C22.2 No. 8, 600/350V

V_R	I_R	I_{leak}	$R_{typ.}$	Approx. Weight
AC V	A	mA	μ ohm	kg. / lbs.
760/440	250	< 28	60	15 / 33

				TOLERANCES (EXCEPT AS NOTED)	7878 N. 86th STREET MILWAUKEE, WI 53224 KRF FILTER KRF0250VCB, 600-690V,250A DRN. BY DSW DATE 1/06/2010 DWG. NO. CKRF0250VCB SCALE TO FIT APPRVD. SHT.1 OF1
				DECIMAL	
				.XX ±.02 .XXX±.01	
				FRACTIONAL ± 1/32	
NO	REVISION	DATE	BY	ANGULAR ± 1/2°	